

DETAIL A
SCALE 1 : 8

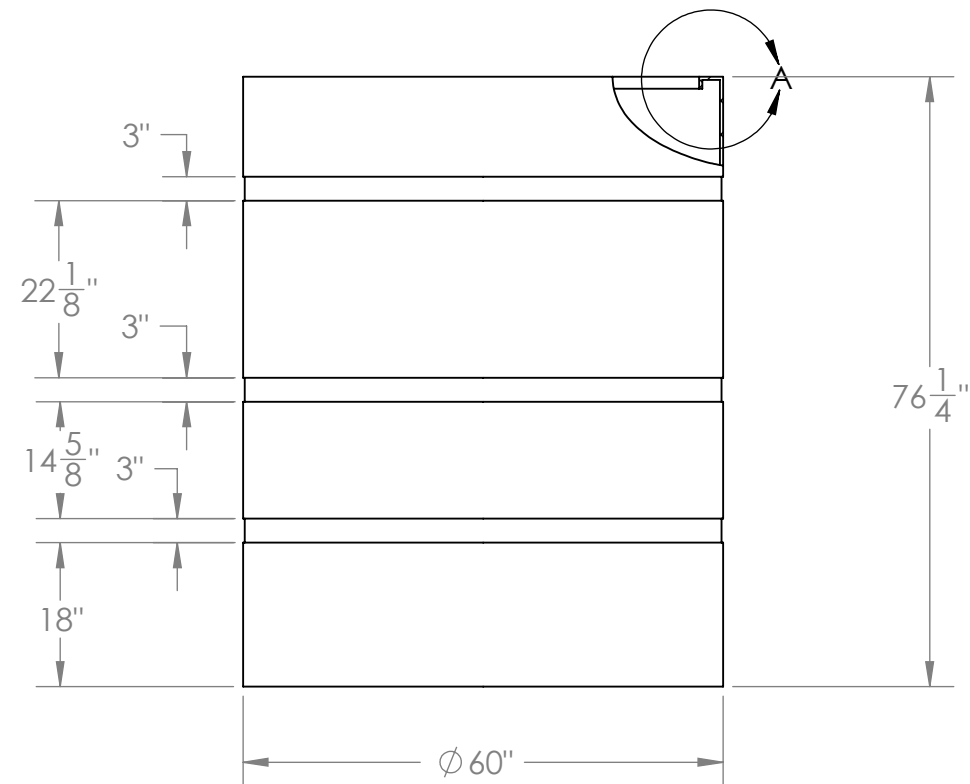
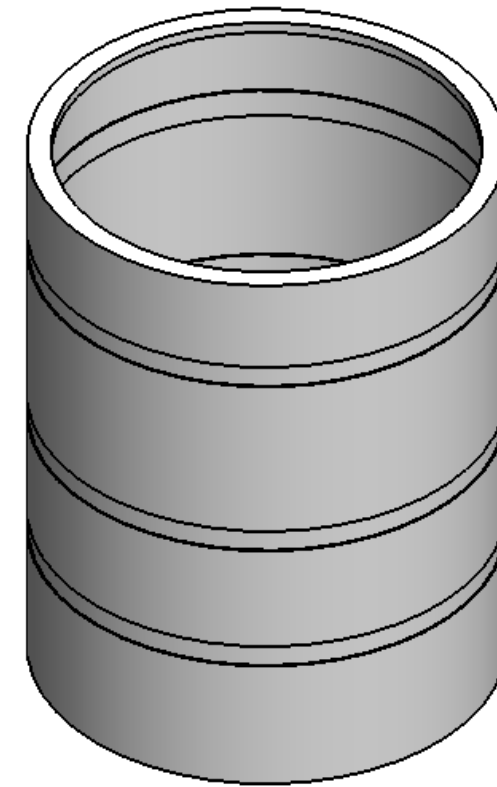

NOTES:

1. MATERIAL: HDPE
2. MOLDED WT. 175 LBS
3. RATED 1.5 S.G.

PROPRIETARY AND CONFIDENTIAL
THE INFORMATION CONTAINED IN THIS DRAWING IS THE SOLE PROPERTY OF <INSERT COMPANY NAME HERE>. ANY REPRODUCTION IN PART OR AS A WHOLE WITHOUT THE WRITTEN PERMISSION OF <INSERT COMPANY NAME HERE> IS PROHIBITED.

		UNLESS OTHERWISE SPECIFIED:	NAME	DATE	CUSTOM ROTO-MOLDING, INC.		
		DIMENSIONS ARE IN INCHES TOLERANCES: FRACTIONAL ± ANGULAR: MACH ± BEND ± TWO PLACE DECIMAL ± THREE PLACE DECIMAL ±	DRAWN	EBW		1-14-11	
		INTERPRET GEOMETRIC TOLERANCING PER:	CHECKED		TITLE: 925 GALLON OPEN TOP TANK		
		MATERIAL	ENG APPR.				
NEXT ASSY	USED ON	FINISH	MFG APPR.		SIZE	DWG. NO.	REV
APPLICATION		DO NOT SCALE DRAWING	Q.A.		B	925 OTT	
			COMMENTS:		SCALE: 1:24	WEIGHT:	SHEET 1 OF 1