

D
C
B
A

D
C
B
A

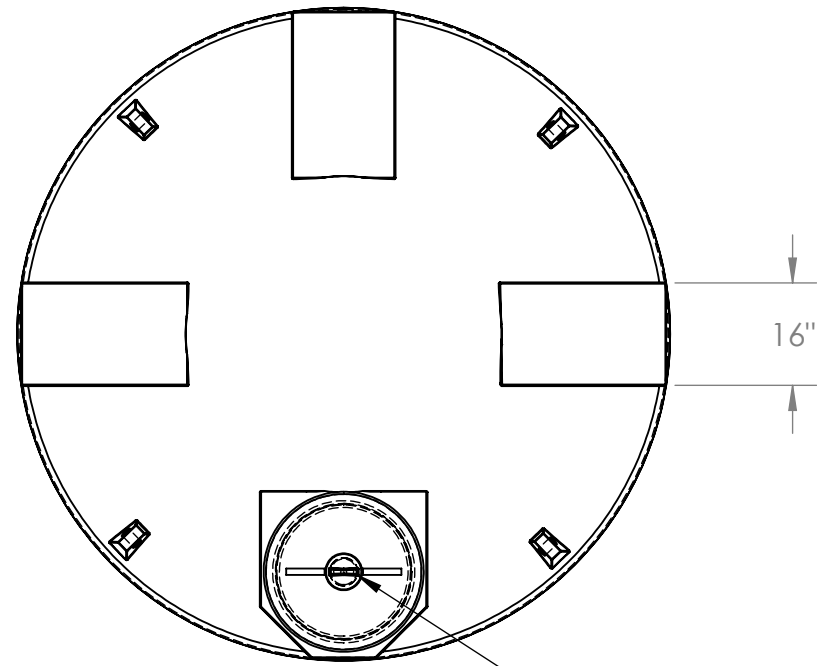

24" THREADED LID
W/4" BREATHER

1 1/2" LIFTING
EYE (4) PLCS

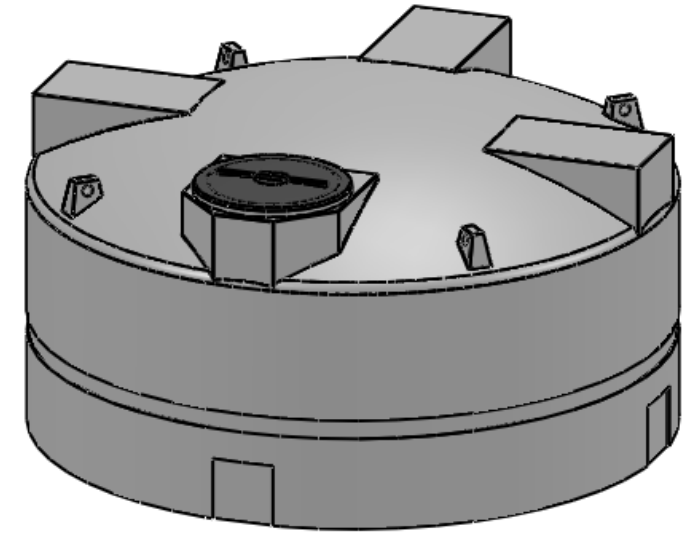

NOTES:

- MATERIAL: POLYETHYLENE
- WEIGHT: STD. RATED 1.5 S.G. 287 LBS
HD. RATED 2.0 S.G. 375 LBS

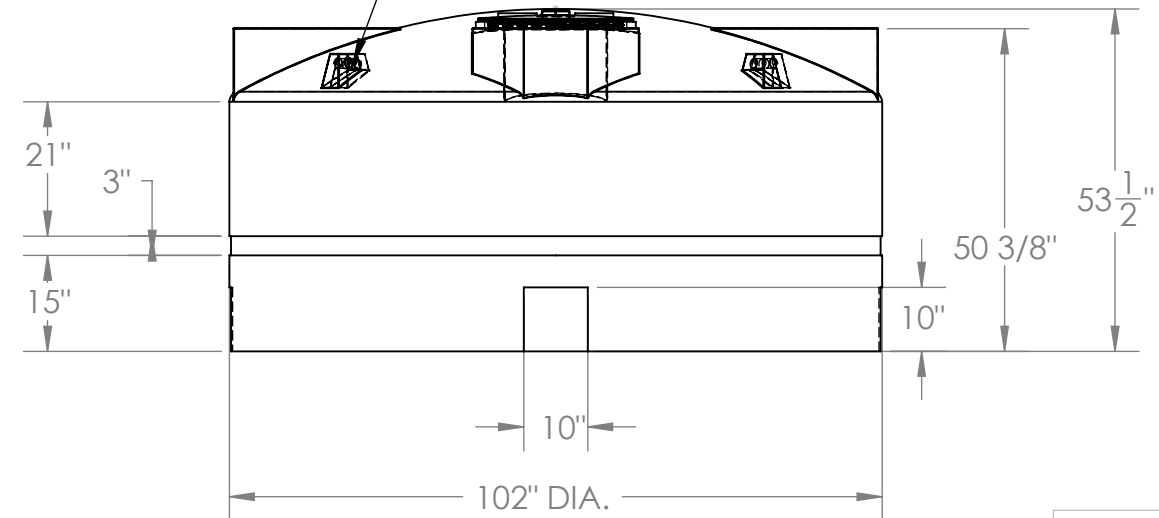

PROPRIETARY AND CONFIDENTIAL
THE INFORMATION CONTAINED IN THIS DRAWING IS THE SOLE PROPERTY OF <INSERT COMPANY NAME HERE>. ANY REPRODUCTION IN PART OR AS A WHOLE WITHOUT THE WRITTEN PERMISSION OF <INSERT COMPANY NAME HERE> IS PROHIBITED.

		UNLESS OTHERWISE SPECIFIED:	NAME	DATE	CUSTOM ROTO-MOLDING, INC.		
		DIMENSIONS ARE IN INCHES TOLERANCES: FRACTIONAL ± ANGULAR: MACH ± BEND ± TWO PLACE DECIMAL ± THREE PLACE DECIMAL ±	DRAWN	EBW		6/4/09	
		INTERPRET GEOMETRIC TOLERANCING PER:	CHECKED		TITLE: 1600 GALLON VERTICAL TANK		
		MATERIAL	ENG APPR.				
NEXT ASSY	USED ON	FINISH	MFG APPR.		SIZE	DWG. NO.	REV
APPLICATION		DO NOT SCALE DRAWING	Q.A.		B	1600 VTS	
			COMMENTS:		SCALE: 1:50	WEIGHT:	SHEET 1 OF 1