

8 7 6 5 4 3 2 1

D
C
B
A

D
C
B
A

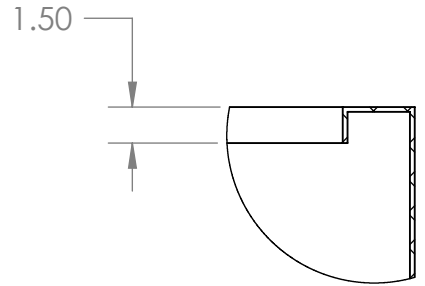
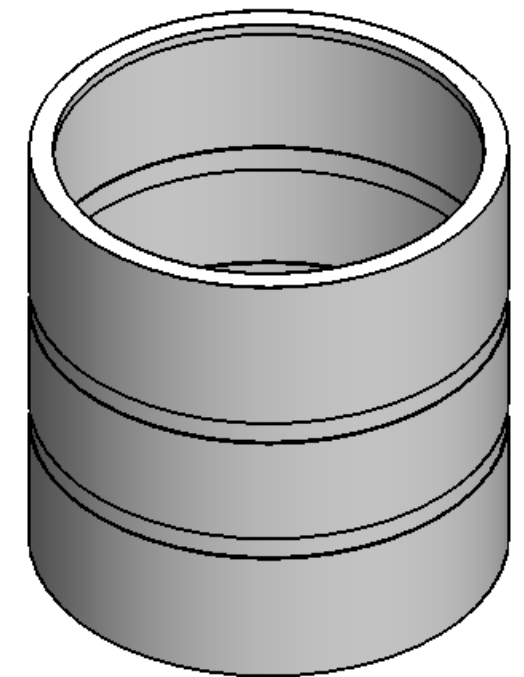
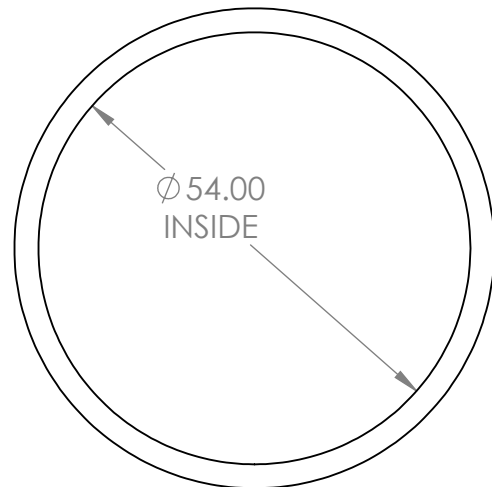

DETAIL A
SCALE 1 : 8

NOTES:

1. MATERIAL: HDPE
2. MOLDED WT. 120 LBS
3. RATED 1.5 S.G.

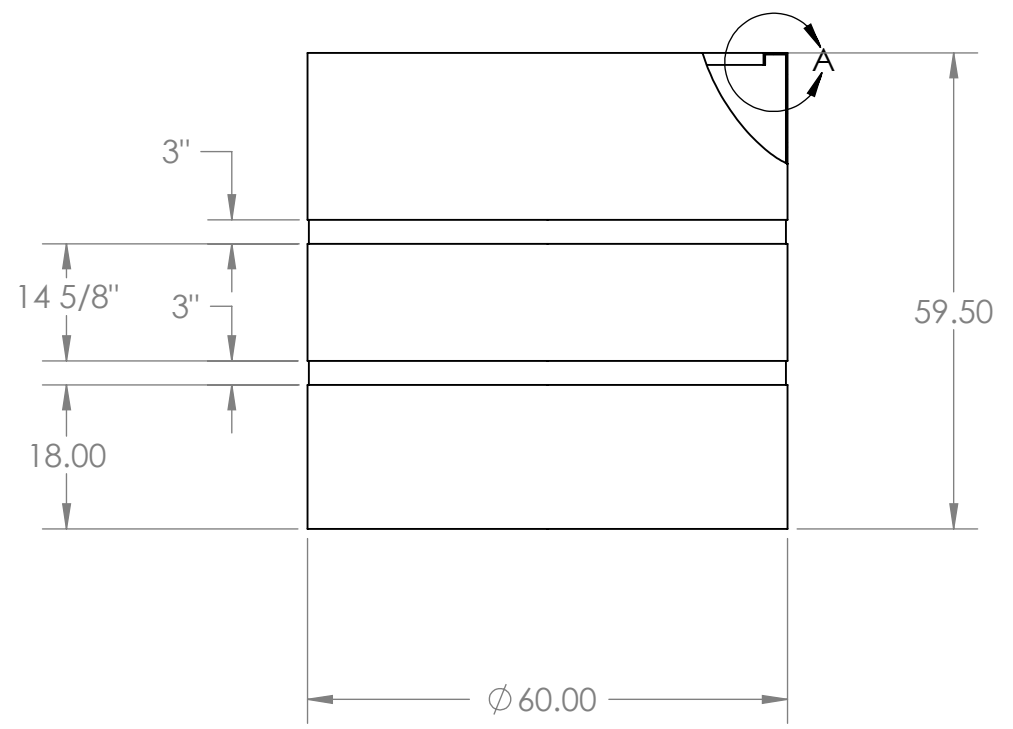

PROPRIETARY AND CONFIDENTIAL
 THE INFORMATION CONTAINED IN THIS DRAWING IS THE SOLE PROPERTY OF <INSERT COMPANY NAME HERE>. ANY REPRODUCTION IN PART OR AS A WHOLE WITHOUT THE WRITTEN PERMISSION OF <INSERT COMPANY NAME HERE> IS PROHIBITED.

		UNLESS OTHERWISE SPECIFIED:		NAME	DATE	CUSTOM ROTO-MOLDING, INC.			
		DIMENSIONS ARE IN INCHES		DRAWN	EBW	1-14-11	TITLE: 700 GALLON OPEN TOP TANK		
		TOLERANCES:		CHECKED					
		FRACTIONAL ±		ENG APPR.					
		ANGULAR: MACH ± BEND ±		MFG APPR.					
		TWO PLACE DECIMAL ±		Q.A.			SIZE	DWG. NO.	REV
		THREE PLACE DECIMAL ±		COMMENTS:			B	700 OTT	
		INTERPRET GEOMETRIC TOLERANCING PER:				SCALE: 1:24		WEIGHT:	SHEET 1 OF 1
		MATERIAL							
		FINISH							
NEXT ASSY	USED ON	DO NOT SCALE DRAWING							
APPLICATION									

8 7 6 5 4 3 2 1